



Enriching Lives

## SUBMERSIBLE SEWAGE PUMPS

TYPE - i-NS



**KIRLOSKAR BROTHERS LIMITED**

# SUBMERSIBLE SEWAGE PUMP TYPE i-NS

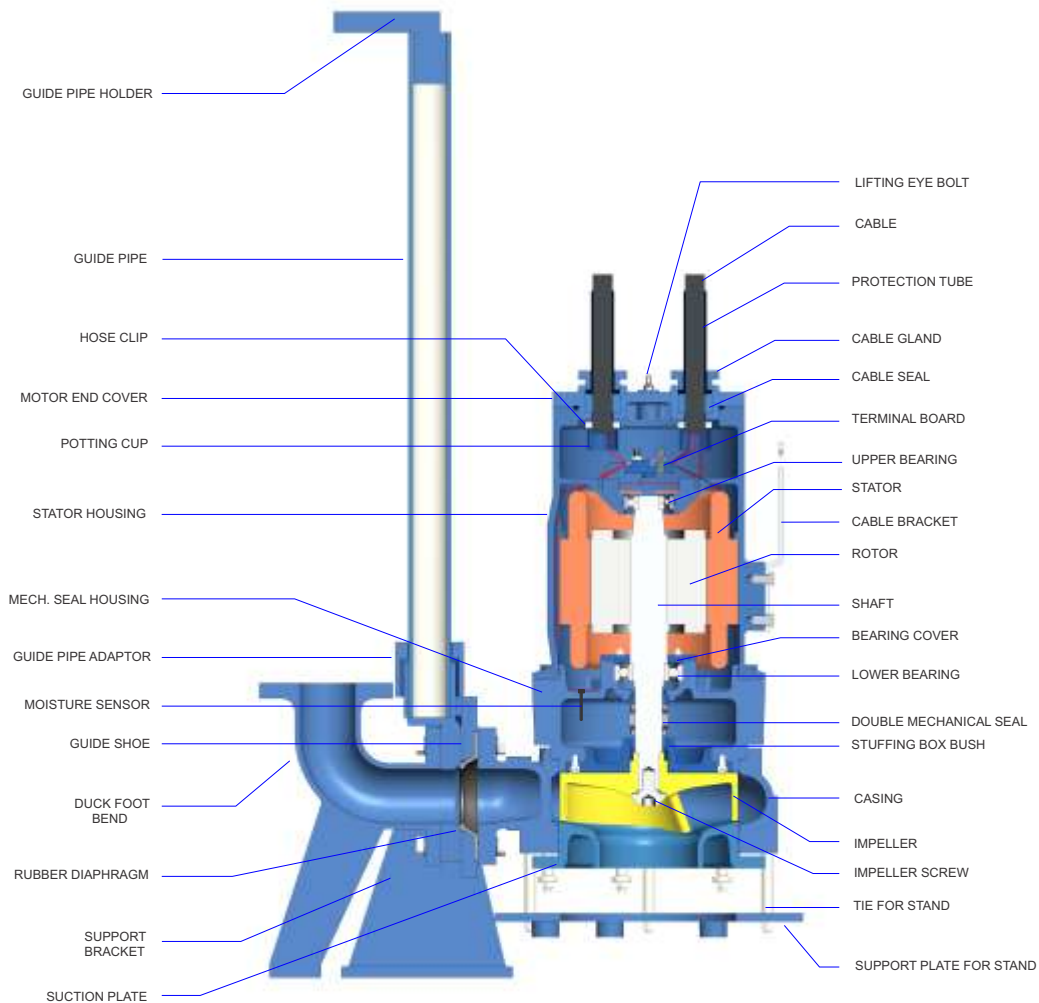

## RANGE

Delivery size : up to 150 mm  
 Capacity (Max) : up to 300 m<sup>3</sup>/hr  
 Head (Max) : up to 50 m  
 Max. Permissible solid size : up to 125 mm  
 Motor rating : up to 22 kw

## APPLICATIONS

- Contaminated Effluents
- Industrial Waste Water
- Storm Water
- Trench and Tunnel Water
- Drain Water
- Saline Water
- Drainage Water
- Sewage Water

Sr. No.	IMPELLER TYPE									TOTAL	Rating in 4 pole								SUM	VARIETY		
	PUMP	N	QM	Q	QT	NB	QMB	NM	QNM		2.2	3.7	5.5	7.5	9.3	11	15	19			22	
1	40/20				*					1	*	*							2	2		
2	40/32				*					1	*	*	*						3	3		
4	50/20				*					1	*	*	*						3	3		
5	50/26	*	*	*	*	*	*			6		*	*	*	*				4	24		
6	50/32	*	*		*					3				*	*	*	*	*	6	18		
7	50/36		*							1					*	*	*	*	4	4		
8	65/32	*	*	*	*	*	*			6				*	*	*	*	*	6	36		
9	80/26	*	*	*	*					4				*	*	*	*	*	6	24		
10	100/26	*	*	*	*					4				*	*	*	*	*	6	24		
11	100/32	*	*	*	*					4					*	*	*	*	4	16		
12	150/26	*	*	*	*	*	*	*	*	8					*	*	*	*	4	32		
13	150/32	*	*	*	*					4							*	*	2	8		
16	80/40	*	*	*	*			*	*	6							*	*	2	12		
TOTAL		9	10	8	12	3	3	2	2	49	3	4	3	5	5	7	7	9	9	52	206	
NO. OF HYDRAULICS WITH VARIOUS IMPELLERS-										49												
NO. OF COMBINATIONS WITH AVAILABLE RATINGS AND HYDRAULICS-																					206	

\*applicable

## CONSTRUCTIONAL FEATURES

These are single suction pumps with overall non clogging impeller. Pump can be officered in stationary as well as transportable arrangements. The stationary arrangement is supplied with pump connector unit and connector unit is connected to pump support bracket with rubber diaphragm to make it leak proof joint

### Pump Casing

The radially split casing is provided with delivery nozzle cast integral with it. Suction is axial and delivery nozzle is central and horizontal. Specially designed semi concentric casing results in reduced radial thrust and ensures vibration free performance. Wide volute passage ensures non clogging operation of the pump.

### Impeller

Impellers are of non clog type which allows smooth passage of solids. Impellers are with two or multi vanes in semi open and enclosed to cater wide application. Following types of impellers are available.

N	Two vanes enclosed type.
NB	Two vanes enclosed type (reduced width)
Q	3 vanes semi-open type.
QM,QNM	2 vanes semi-open impeller (with cutting & tearing arrangement)
QT	3 or 5 vanes semi-open impeller (with cutting & tearing arrangement)
QMB	2 vanes semi-open impeller (reduced width with cutting & tearing arrangement)
NM	Two vanes enclosed type with modified outlet width.

### Shaft

The high tensile steel shaft accurately machined and ground is supported by two ball bearings in the motor above the impeller. Shaft is designed to transmit the power without undue vibrations and deflections. The shaft is common for pump and motor of monoblock design.

### Mechanical Seals

Double mechanical seal with back to back arrangement is provided to ensure no ingress of pumping liquid in the motor.

### Optional Features

Pumps can be supplied with "cutter fan" arrangement at suction to agitate the liquid.

Semi-open impellers can be provided with specially designed wear plate for cutting and tearing of soft, long fibrous materials.

### Bearings

Bearing are grease lubricated and sealed for life, hence maintenance free.

### Direction Of Rotation

Direction of rotation is clockwise when viewed from motor top.

### Drive

Motor is dry type submersible and cooled by liquid being handled.

Motors are air tested for leak proof operation.

Degree of Protection for Motor: IP68 as per IS: 2147

Class of Insulation: F

Voltage: 415 V +/-10%

Frequency: 50Hz +/- 5%

Type of Starting: DOL up to 9.3 KW 4 Pole and SDS beyond 9.3 KW 4 Pole.

### Cable

A specially designed cable with 1.1 KV grade, annealed tinned copper conductor, insulated with Electron beam irradiated cross linked elastomeric compound [compatible for continuous operation up to 120C] cores laid up with a proof cotton binder tape and sheathed overall with electron beam irradiated cross linked HD HOFER [Heavy duty, Heat, Oil, Fire retardant] elastomeric compound and generally conforming to IS: 9968, Part-I. The cable with this unique combination of insulating and sheathing material offers best resistance to acidic or alkaline sewage medium and to the effluent gases coming out of the sump. The cable is more flexible than the PVC cable making coiling and handling easier and light in weight compared to PVC cable of the same size.

### Control Panel

Control panel consist of starter, switch, fuse and safety features.

Safety features are:

Single phasing prevention

Overload /under voltage/ reverse phasing relays

Moisture sensing unit for detecting ingress of moisture or water into the oil chamber

Liquid level controllers to avoid dry running

Thermister sensing unit for High temperature at the motor winding.

### Flanges

Standard drilling to IS: 6392 table 15//BSEN1092 PN16

## NEW FEATURES

### 1. Motor End Cover:

1. New motor end cover with compact design.
2. Aesthetically improved



### 2. Stator Housing:

1. Integrated design of stator housing and upper bearing holder.
2. Pipe design.



### 3. Mechanical Seal Housing:

1. Integrated design of casing cover and lower bearing holder.



### 4. Stand:

1. Modified design with stud and plate design.



### 5. Duck Foot Bend:

1. Bend with short design.
2. Integrated ribs as cast with bend.



### 6. Support Bracket:

1. Support bracket suitable for single guide pipe design.



### 7. Guide Shoe:

1. Guide shoe suitable for single guide pipe design.
2. Aesthetical improvement.



### 8. Guide Pipe Adapter:

1. New part introduced to support the guide pipe.



### 9. Chain:

1. Intermediate rings introduced for pulling the pump.



### 10. Guide Pipe Holder:

1. Guide pipe holder suitable for single guide pipe design.
2. Easy fitment.



## NEW FEATURES

### 11. Single Guide Pipe Connector Unit

#### 12. Cable Bracket:

1. Cable to be wound around the stator housing taking the help of cable bracket.  
This reduces the cable damage problem drastically.



#### 13. Terminal Board:

1. Introducing plate type terminal board with good aesthetic look and in compact design.  
2. Intermediate ribs provided to reduce the chances of short circuit.



#### 14. Hose Clip:

1. Introducing the hose clip, to reduce cable damage while pulling the pump from pit.



#### 15. Cable Gland:

1. Introducing new cable gland with compact design.  
2. Aesthetically improvement.



#### 16. Potting Cup:

1. Introducing newly developed potting cup to reduce the chances of leakage of liquid towards the motor.



# FOUNDATION PLAN DRAWING (STATIONARY INSTALLATION)

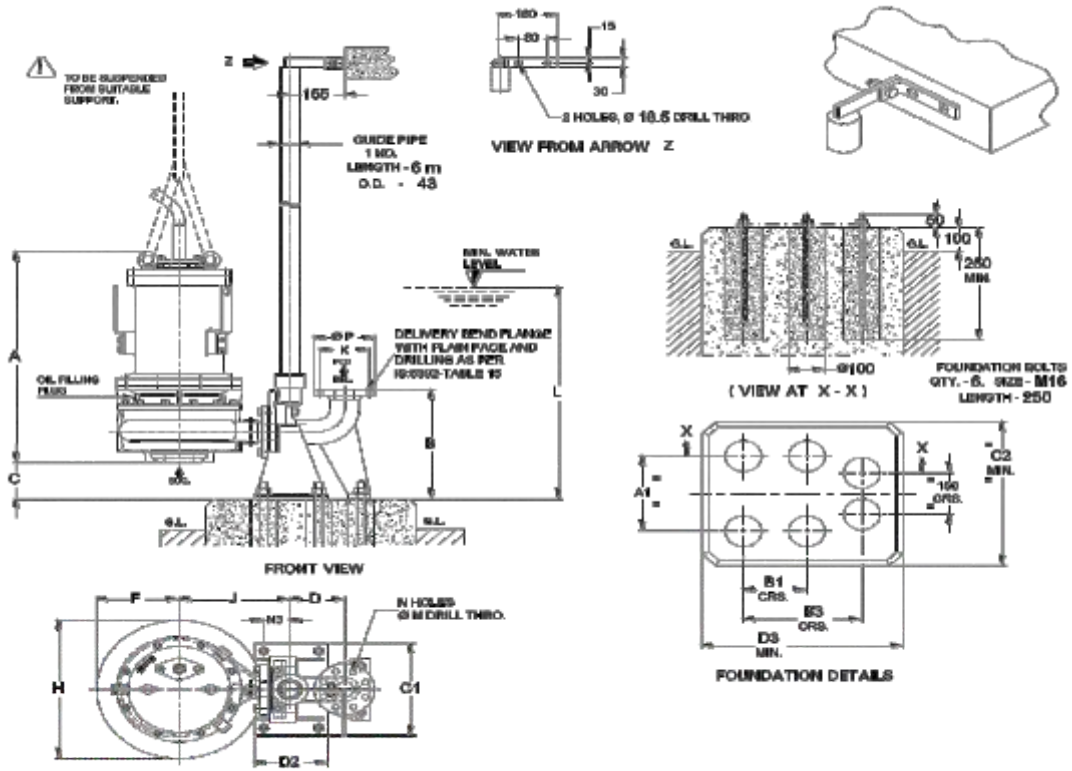

PLAN OF PUMP AND CONNECTOR UNIT ONLY

ÚP Ů	A	C	B	D	J	F	N3	H	C1	A1	D2	B1	B3	D3	C2	L	K	ØP	N	ØM	UNIT
NS40/20QT	633	126	350	147	258	190	74	380	320	260	200	150	221	521	560	550	110	150	4	18	I
NS40/32QT	681	100	350	147	333	248	74	495	320	260	200	150	221	521	560	550	110	150	4	18	
NS50/20QT	634	175	425	147	288	190	74	380	325	260	200	150	286	586	560	600	125	165	4	18	
NS50/26N/NB/Q	686	150	425	147	303	230	74	460	325	260	200	150	286	586	560	600	125	165	4	18	
NS50/26QM/QMB/QT	671	165	425	147	303	230	74	460	325	260	200	150	286	586	560	600	125	165	4	18	
NS100/26N/Q	799	170	490	197	334	230	104	460	350	325	280	230	336	636	625	750	180	220	8	18	II
NS100/26QM/QT	793	176	490	197	334	230	104	460	350	325	280	230	336	636	625	750	180	220	8	18	
NS100/32N/Q	900	170	490	197	369	219	104	438	350	325	280	230	336	636	625	850	180	220	8	18	
NS100/32QM/QT	900	170	490	197	369	245	104	490	350	325	280	230	336	636	625	850	180	220	8	18	
NS150/26N/NB/NM/Q	930	185	553	224	415	238	125	475	450	420	355	280	406	706	720	900	240	285	8	23	
NS150/26QM/QMB/QNM/QT	820	194	553	224	415	238	125	475	450	420	355	280	406	706	720	800	240	285	8	23	
NS50/26N/NB/Q	764	150	425	147	303	230	74	460	325	260	200	150	286	586	560	700	125	165	4	18	
NS50/26QM/QMB/QT	749	165	425	147	303	230	74	460	325	260	200	150	286	586	560	700	125	165	4	18	
NS50/32N	774	140	425	147	338	230	74	460	325	260	200	150	286	586	560	700	125	165	4	18	
NS50/32QM/QT	763	151	425	147	338	245	74	490	325	260	200	150	286	586	560	700	125	165	4	18	
NS50/36QM	780	131	425	147	388	283	74	565	325	260	200	150	286	586	560	700	125	165	4	18	
NS65/32N/NB/Q	774	140	450	172	333	230	79	460	325	270	225	175	304	604	570	700	145	185	4	18	
NS65/32QM/QMB/QT	764	150	450	172	333	245	79	490	325	270	225	175	304	604	570	700	145	185	4	18	
NS80/26N/Q	779	150	490	177	303	230	84	460	350	300	250	200	331	631	600	700	160	200	8	18	
NS80/26QM/QT	801	128	490	177	303	230	84	460	350	300	250	200	331	631	600	700	160	200	8	18	
NS100/26N/Q	900	170	490	197	334	230	104	460	350	325	280	230	336	636	625	850	180	220	8	18	
NS100/26QM/QT	894	176	490	197	334	230	104	460	350	325	280	230	336	636	625	850	180	220	8	18	
NS100/32N/Q	799	170	490	197	369	219	104	438	350	325	280	230	336	636	625	750	180	220	8	18	
NS100/32QM/QT	821	148	490	197	369	245	104	490	350	325	280	230	336	636	625	750	180	220	8	18	
NS150/26N/NB/NM/Q	829	185	553	224	415	238	125	475	450	420	355	280	406	706	720	800	240	285	8	23	
NS150/26QM/QMB/QNM/QT	921	194	553	224	415	238	125	475	450	420	355	280	406	706	720	900	240	285	8	23	
NS150/32N/Q	925	190	553	224	460	240	125	480	450	420	355	280	406	706	720	900	240	285	8	23	
NS150/32QM/QT	931	200	553	224	460	245	125	490	450	420	355	280	406	706	720	900	240	285	8	23	
NS50/32N	875	140	425	147	338	230	74	460	325	260	200	150	286	586	560	800	125	165	4	18	
NS50/32QM/QT	864	151	425	147	338	245	74	490	325	260	200	150	286	586	560	800	125	165	4	18	
NS50/36QM	881	131	425	147	388	283	74	565	325	260	200	150	286	586	560	800	125	165	4	18	
NS65/32N/NB/Q	875	140	450	172	333	230	79	460	325	270	225	175	304	604	570	800	145	185	4	18	
NS65/32QM/QMB/QT	865	150	450	172	333	245	79	490	325	270	225	175	304	604	570	800	145	185	4	18	
NS80/26N/Q	880	150	490	177	303	230	84	460	350	300	250	200	331	631	600	800	160	200	8	18	
NS80/26QM/QT	902	128	490	177	303	230	84	460	350	300	250	200	331	631	600	800	160	200	8	18	
NS80/40N/NM/Q	880	165	490	177	408	265	84	530	350	300	250	200	331	631	600	800	160	200	8	18	
NS80/40QM/QNM/QT	907	138	490	177	408	285	84	570	350	300	250	200	331	631	600	800	160	200	8	18	

# OUTLINE DRAWING (PORTABLE PUMP)

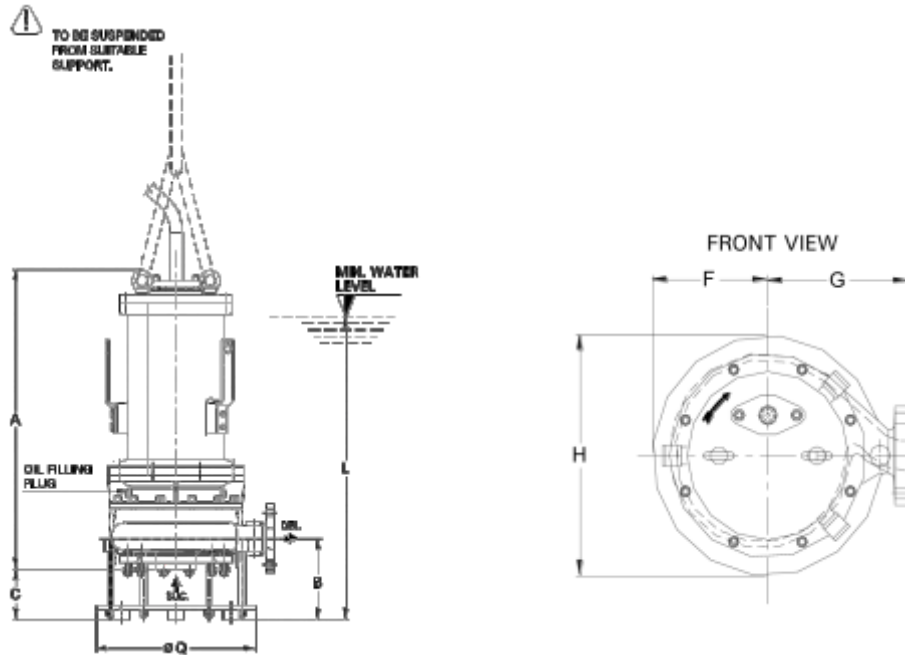

Ú×P Û	A	B	C	F	G	H	K	M	N	P	Q	L	portable
NS40/20QT	633	150	76	213	200	425	110	150	4	18	400	550	unit I
NS40/32QT	681	149	49	260	275	520	110	150	4	18	500	550	
NS50/20QT	634	250	180	213	230	425	125	165	4	18	400	600	
NS50/26N/NB/Q	686	250	170	230	245	460	125	165	4	18	450	600	
NS50/26QM/QMB/QT	671	250	170	250	245	500	125	165	4	18	450	600	
NS100/26N/Q	799	290	215	230	275	460	180	220	8	18	450	750	unit II
NS100/26QM/QT	793	290	180	275	275	550	180	220	8	18	450	750	
NS100/32N/Q	799	290	255	250	310	500	180	220	8	18	500	750	
NS100/32QM/QT	821	290	185	288	310	575	180	220	8	18	500	750	
NS150/26N/NB/NM/Q	829	325	295	230	350	460	240	285	8	23	475	800	
NS150/26QM/QMB/QNM/QT	820	325	190	288	350	575	240	285	8	23	475	800	
NS50/26N/NB/Q	764	250	215	230	245	460	125	165	4	18	450	700	
NS50/26QM/QMB/QT	749	250	170	250	245	500	125	165	4	18	450	700	
NS50/32N	774	250	225	250	280	500	125	165	4	18	500	700	
NS50/32QM/QT	763	250	155	270	280	540	125	165	4	18	500	700	
NS50/36QM	780	250	135	308	330	615	125	165	4	18	625	700	
NS65/32N/NB/Q	774	250	210	250	275	500	145	185	4	18	500	700	unit III
NS65/32QM/QMB/QT	764	250	150	270	275	540	145	185	4	18	500	700	
NS80/26N/Q	779	265	235	230	245	460	160	200	8	18	450	700	
NS80/26QM/QT	801	265	160	250	245	500	160	200	8	18	450	700	
NS100/26N/Q	900	250	265	230	275	460	180	220	8	18	450	850	
NS100/26QM/QT	894	250	180	275	275	550	180	220	8	18	450	850	
NS100/32N/Q	900	250	260	250	310	500	180	220	8	18	500	850	
NS100/32QM/QT	900	250	185	288	310	575	180	220	8	18	500	850	
NS150/26N/NB/NM/Q	930	325	295	230	350	460	240	285	8	23	475	900	
NS150/26QM/QMB/QNM/QT	921	325	190	275	350	550	240	285	8	23	475	900	
NS150/32N/Q	925	325	293	250	395	500	240	285	8	23	500	900	
NS150/32QM/QT	931	325	200	288	395	575	240	285	8	23	500	900	
NS50/32N	875	250	225	250	280	500	125	165	4	18	500	800	
NS50/32QM/QT	864	250	155	270	280	540	125	165	4	18	500	800	
NS50/36QM	881	250	135	308	330	615	125	165	4	18	625	800	
NS65/32N/NB/Q	875	250	210	250	275	500	145	185	4	18	500	800	
NS65/32QM/QMB/QT	865	250	150	270	275	540	145	185	4	18	500	800	
NS80/26N/Q	880	265	235	230	245	460	160	200	8	18	450	800	
NS80/26QM/QT	902	265	160	250	245	500	160	200	8	18	450	800	
NS80/40N/NM/Q	880	265	490	275	350	550	160	200	8	18	550	800	
NS80/40QM/QNM/QT	907	265	490	325	350	650	160	200	8	18	650	800	

i-NS PUMPS FAMILY RANGE AT 1450 RPM

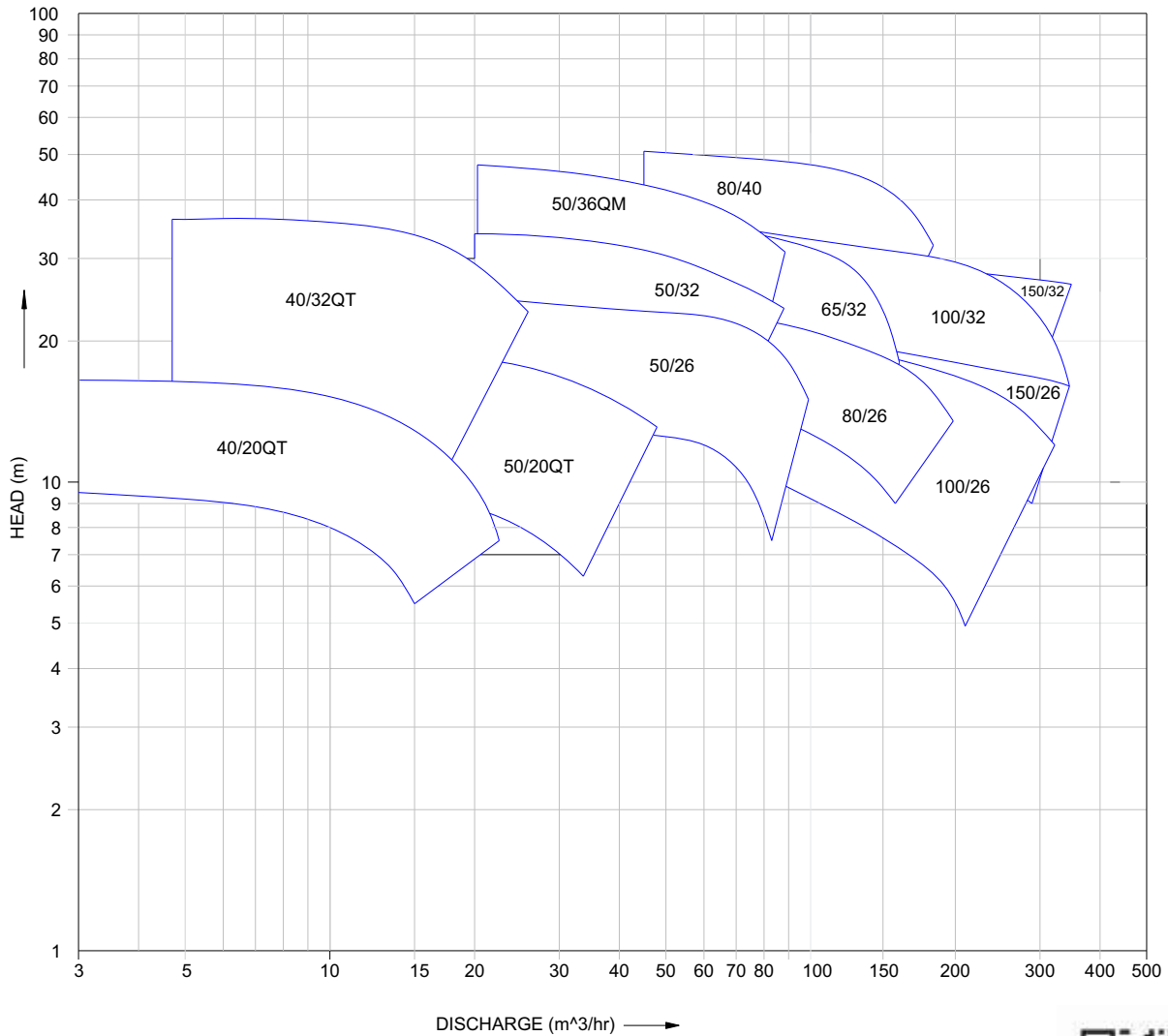

Scan this code with your smart phone to know more about KBL

As we are constantly endeavouring to improve the performance of our products / equipment, we reserve the right to make alterations from time to time and as such our products / equipments may differ from that detailed in this publication. For latest information you may get in touch with our Regional Sales Offices.



Enriching Lives

**KIRLOSKAR BROTHERS LIMITED**

A Kirloskar Group Company

**GLOBAL HEADQUARTERS :**

“YAMUNA”, Survey No. 98 (3 to 7), Baner,  
Pune - 411045, INDIA  
Tel.: +91-20 27214444 Fax : +91-20 27211117  
email : kblin@kbl.co.in Website : www.kirloskarpumps.com

**REGISTERED OFFICE :**

Udyog Bhavan, Tilak Road,  
Pune - 411002, INDIA  
Tel.: +91-20 24440770 Fax: +91-20 24440156

**WORKS :**

Kirloskarvadi 416308 Dist. Sangli  
Maharashtra, INDIA  
Tel.: +91 2346 222301 to 222305 Fax: +91 2346 222311

Our Companies



i-NS-10-2015-01