



**INSTRUCTIONS
ON
INSTALLATION,
OPERATION
AND
MAINTENANCE

FOR
KIRLOSKAR
PUMP TYPE
" CF "**

WARRANTY

We warrant that the pump supplied from us is free from defective material and faulty workmanship. This warranty holds good for a period of 12 months from the date of commissioning the equipment or 18 months from the date of despatch from our factory, whichever is earlier. Our liability in respect of any complaint is limited to replacing part/parts free of charge ex-works or repairs of the defective part/parts only to the extent that such replacement / repairs are attributable or arise solely from faulty workmanship or defective material.

This warranty holds good only for the products manufactured by us.

- KIRLOSKAR BROTHERS LIMITED

CONTENTS

1. GENERAL.
2. INSTALLATION.
3. OPERATION.
4. TECHNICAL DATA.
5. MAINTENANCE.
6. OVERHAULING.
7. SPARE PARTS LIST AND
CROSS SECTIONAL DRAWING.

1. GENERAL:

1.1 The booklet covers instructions for following types of CF series horizontal pumps.

CF 110 (CF 111 to CF 118)

CF 220 (CF 221 to CF 228)

CF 330 (CF 331 to CF 338)

CF 440 (CF 441 to CF 448)

CF 550 (CF 551 to CF 558)

1.2 Cold model pumps (without stuffing box cooling arrangement) are supplied for clear liquid having temperature up to 90 degree C. Above 90 degree C, stuffing box cooling arrangement is required and are suitable up to 120 degree C.

1.3 Pumps, when properly installed and given due care in operation and maintenance, should operate satisfactorily for a long period of time, when the pump is received sometime before the actual use of the pump, it should be indicated and located in a dry place. The coupling should be rotated once in a month to prevent pitting of bearing surfaces.

1.4 Each pump is subjected to a functional test prior to shipment. The manufacturer only warrants the correct functioning of the pump-set on condition that it is installed and started up in full compliance with the instructions contained in this manual. In the event of a warranty claim the pump must not be opened. Any manipulations performed on the pump by a third party shall release the manufacturer from his warranty obligations.

The nameplate of the pump/pump-set states the pump number, type designation and the given duty data. The pump shall only be operated at the duty data stated in the purchase order.

Queries, orders for spare parts etc can only be handled if the pump number is indicated.

These operating instructions do not overrule local safety regulations.

1.5 APPLICATION :

Performance of the side channel pump depends on the clearance between impeller and stage casing [between 0.15 and 0.17 mm wide]. Due to the very less clearances the pump is not suitable for delivery of liquids containing solids with a grain size larger than 60 microns [in some cases a filter can be fitted on the suction side].

The pump must be supplied with liquid at all times; it must never run dry!

The power requirement increases with increasing head and decreasing flow rate.

Never run the pump with the suction and/or discharge line closed!

1.6 TRANSPORT :

The pump must be transported as illustrated in Fig.1. Do not lift the unit by the eye rings on the motor.

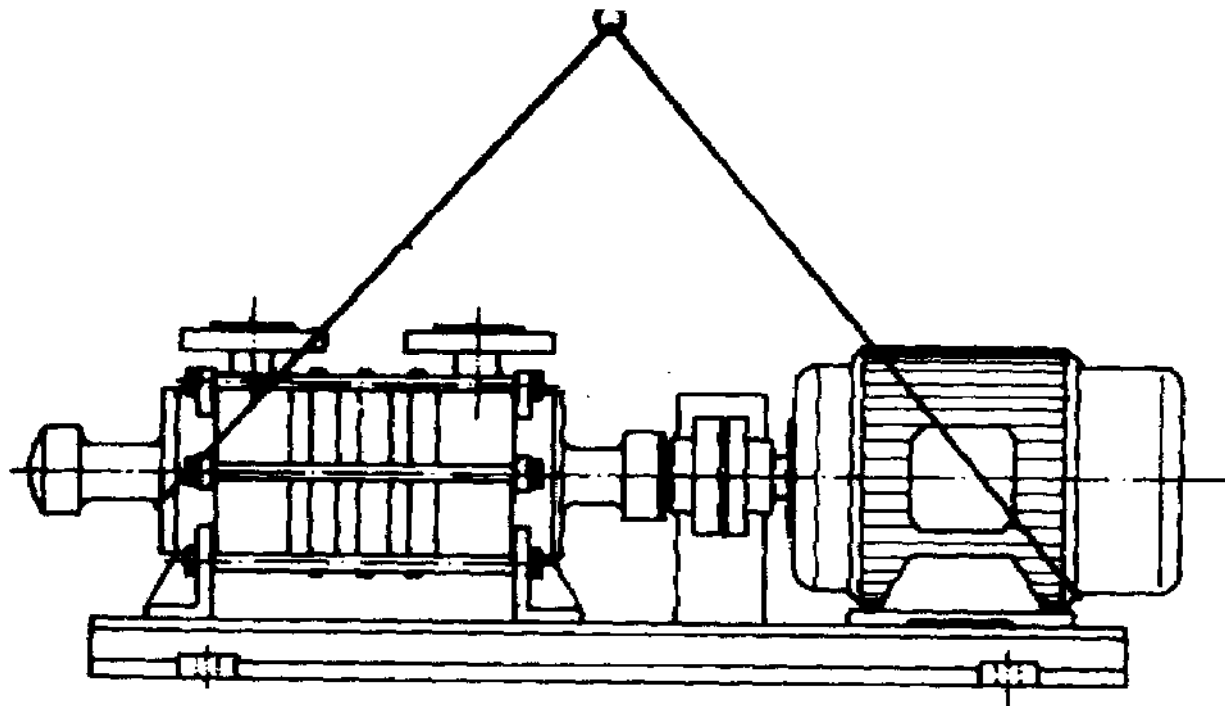

Fig. 1

2. INSTALLATION :

2.1 Pump / Pump-set –

Place pump and driver in aligned condition and free from stresses onto the baseplate. Leave protective plugs of the nozzles in place until connecting the piping. If the motor is not installed together with the pump, the set must be aligned. To do this, make sure the two coupling halves are 100% flush. (See fig. 2). For other types of coupling, see documentation provided by the manufacturer.

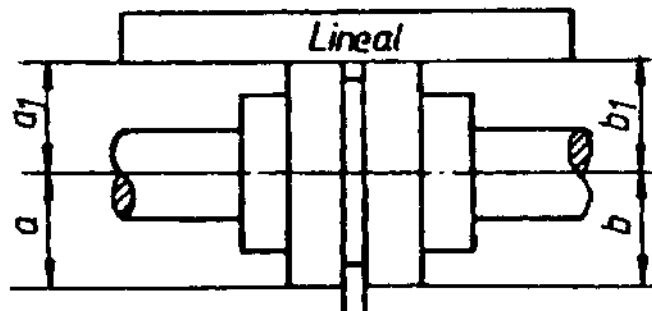

Fig. 2

Never mount couplings using force [e.g. blows with a hammer]. After completing the foundation and connecting the piping, check alignment of the coupling once more and again, if required. To prevent accidents, it is necessary to use coupling guard.

2.2 Piping -

Before connecting the piping, remove the anticorrosive agent filled into the pump before shipment [this only applies to pumps made from gray cast iron].

Suction and delivery flanges should be properly connected to respective piping.

Connect all pipes making sure that no forces/moments resulting from the system can be transmitted to the pump/driver. The effects of stresses resulting from temperature fluctuations shall be minimized by making adequate provisions.

Make sure all pipes are completely clean before commencing commissioning/start-up. Gaskets must be perfectly flush with the inside walls. Check all connections for leakage.

Do not fit small-angle bends in suction or discharge line. The additional connections required for this pump/driver [for cooling liquid, sealing liquid, etc] are indicated separately.

Suction line –

To ensure operation free from cavitation, observe section 2.3 [inlet conditions] of this manual. The diameter of the suction pipeline shall not be less than the suction size of the pump. With positive suction operation from a tank under vacuum, it is advisable to fit a vacuum balance line.

N.B.:

To maintain the self-priming feature of the pump, it must be ensured that pump is always filled with the liquid.

Discharge line –

The size of discharge pipe should be such that its diameter is at least as large as the cross section of the pump discharge flange.

2.3 Inflow conditions [NPSH] -

Pay close attention to the suction head or NPSH-value of liquids pumped at near boiling point, because non-observance could cause the pump to run under cavitation, which, in turn, could destroy the hydraulic parts.

The decisive factors for determining the NPSH-available value are temperature, vapour pressure, density, suction head and pipe loss.

2.4 Valves -

Fit the pump with a manometer/vacuum gauge or pressure gauge on both suction and discharge sides.

A throttle valve is to be fitted on the discharge side in order to maintain the exact delivery head [see name plate].

Make sure the pump is always filled with the pumping liquid to maintain the self-priming feature of the pump. Fit a non-return valve to stop reverse flow of the liquid with suction lift operation

2.5 Checks -

After completing installation of the pump-set, check all piping and connections for leakage. Check piping to ensure free from blockage. It must be possible to rotate the shafting of smaller sized pump-sets by hand. Check the operational safety of the entire pumping plant on the basis of the applicable accident prevention regulations [electrical connections, coupling guard, etc].

3. COMMISSIONING/START-UP/OPERATION:

3.1 Preparations –

Fill the pump with the liquid to be pumped and vent it by means of the vent nipples on the flanges. Pumps in mechanical seal construction must be vented too, by means of screwed plugs, provided on the mechanical seal cover. Venting is also necessary in case of positive suction and for hot liquids.

Pump is to be filled only once and may be filled prior to connecting the piping to suction and delivery flanges. For all subsequent start-ups the pump will operate with self-priming.

Check that the shaft rotates freely. Check that all auxiliary connections are ready for operation.

Open all shutoff valves in suction and discharge lines!

Never start up the pump with the discharge side closed! If the unit is fitted with a bypass line, see that it is closed for suction lift operation; with positive suction it may remain open.

As the bearings are permanently packed with grease, no further greasing is required. Bearings used are self-lubricated.

3.2 Motor –

Check the operating voltage and speed of the motor.

The speed of the 50 Hz model is 1450 rpm. The speed of the 60 Hz model is 1750 rpm.

Provide a motor tripping device!

Check the direction of rotation of the motor with respect to pump by switching the motor on and then off again immediately. The direction of rotation of the pump is indicated on the pump by direction arrow nameplate.

Never run the pump in reverse direction of rotation!

The electrical connections are to be made by an authorized electrician and in compliance local regulations, in particular in respect of the safety measures to be performed.

3.3 Start-up –

Switch the pump on with the shutoff valves open.

The valves incorporated in the suction line must also be open!

Close bypass line.

Once the pump has reached full speed [rated speed indication on the rating plate], adjust the delivery head by slowly closing the valve on the discharge side.

The time required for suction to start depends on the length of the suction line and will take several seconds at first start up. If the suction line is fitted with a foot or non-return valve, delivery will start immediately the second time the unit is switched on.

3.4 OPERATION :

3.4.1 General –

Never run the pump without liquid or with a prolonged interruption of the flow.

Pump and motor should run smoothly, quietly and free from vibrations at all times. All shut off valves, filters, etc on the suction side are to be remain completely open.

3.4.2 Delivery data –

The delivery head of the pump is indicated on the nameplate. Monitor the required delivery head by observing the pressure gauge reading and readjust on the discharge side valve in the event of a deviating value.

3.4.3 Bearing arrangement –

The temperature of the bearings should not exceed 80°C.

3.4.4 Shaft seal –

The stuffing box of the pump fitted with gland packing should leak a little during operation. To prevent dry running, loosen the stuffing box gland as required.

Mechanical seals do not require maintenance and do not leak during operation.

3.4.5 Cooling of the shaft seal housing –

The shaft seal housing of pumps may be cooled as required. Unscrew the plugs provided on the pump foot and connect the cooling lines.

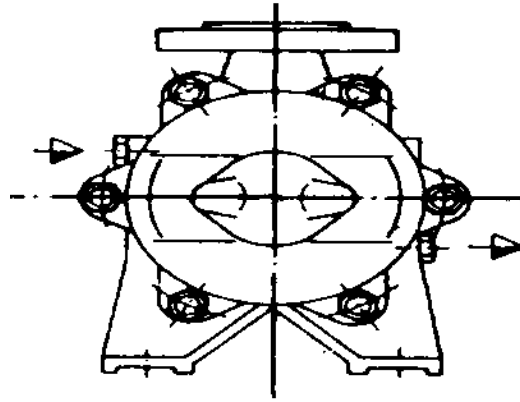

Fig. 3

3.4.5.1 Cooling of the shaft seal housing –

Cooling of the shaft seal housing is recommended when the temperature of the liquid to be pumped exceeds 90°C. The cooling water requirement depends on the temperature of the pumping liquid and on the pump size. It is about 2 l/m at max. 2 bar. The cooling liquid enters the housing in the upper section of the pump foot, whereas it drains off diagonally across on the opposite side [see Fig. 3].

3.4.6 Sealing liquid connection for pump with stuffing box –

It is recommended to use stuffing box sealing.

3.4.7 Operating of the pump used as boiler feed pump –

When the pump is employed as boiler feed pump, care must be taken that it is not run at a lower operating pressure than specified. If the feed tank is operated at a lower operating pressure for any length of time, the pump discharge pressure must be reduced to the normal operating pressure of the tank by means of a hand operated shut off valve and a pressure gauge fitted at the discharge nozzle of the pump casing.

3.4.8 Coupling –

As soon as the flexible elements of the shaft connection show signs of wear [abrasion], these parts have to be replaced. Verify the alignment of the shaft ends.

3.5 SHUT DOWN:

Do not close the shutoff valve on the discharge side until the pump has come to a complete standstill.

Switch off the driver.

The shutoff valves need not be closed if non-return valves are fitted.

The shutoff valve on the suction side is to be closed both during prolonged standstill of the pump and if there is an overpressure on the suction side [positive suction].

Shut down all auxiliary facilities [cooling liquid, etc]. The shaft seal on pumps pumping liquid under vacuum has to remain wetted by the sealing liquid also during standstill.

If there is a danger of frost, protect the pump, cooling circuit, etc against freezing or drain off the liquid.